

N-Channel Scalable Coherent Transceiver

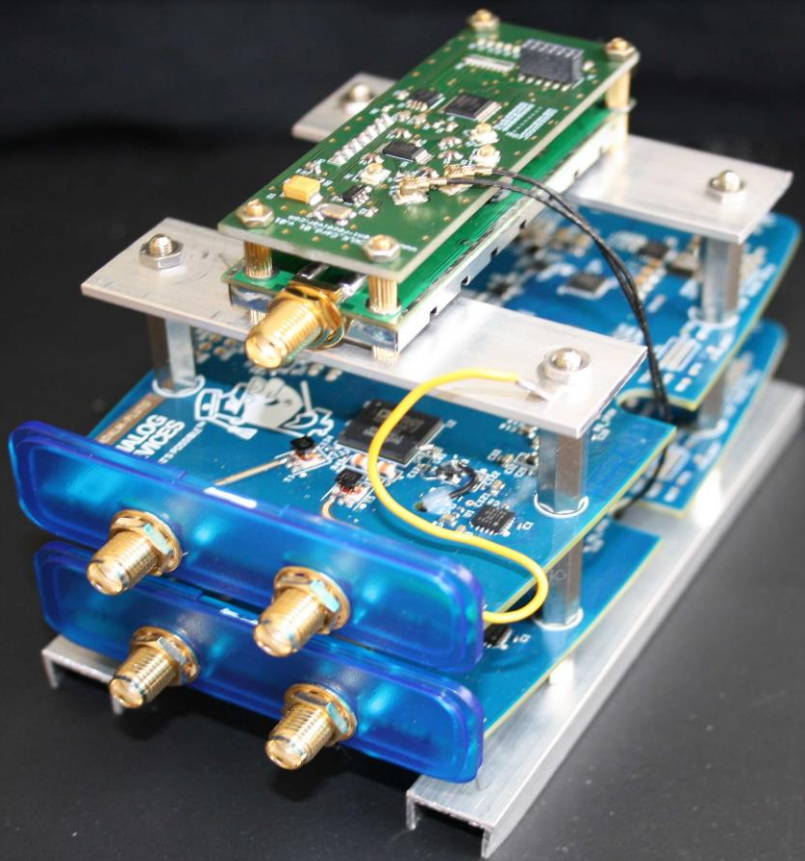

N-Channel Scalable Coherent Transceiver

Coherent transceiver family based on the ADALM-PLUTO SDR

TR0x is an N-channel scalable coherent transceiver that employs the ADALM-PLUTO SDR transceiver in order to create inexpensive multi-channel systems. Reconfigurable design techniques deliver high system performance, flexibility and small board space requirements. All these factors enable the use of the TR0x in many new, previously unavailable application scenarios.

Key Features and Benefits

Scalability from 2 up to 64 and more channels

Integrated common internal TCXO
10/28.8/40 MHz, 2 ppm. Higher precision, e.g. 0.1, 0.2, 0.5, 1.0 ppm, available on request.

Support of external CLK, e.g. 10.0 MHz

Identical form-factor

Cost effective open source software

GNU Radio and MATLAB integration

Configuration

N adapted PLUTO-SDR transceiver

(N) - Pigtails

CLK_CARD10

EXP_CARD (optional)

Applications

- ✓ Coherent receiving
- ✓ Signal decoding improvement
- ✓ Passive radars
- ✓ Radiolocation and Earth exploration
- ✓ Synchronized receiving on the different frequencies
- ✓ Distributed coherent experiments
- ✓ Direction finding (pseudo-Doppler and Watson-Watt technique)
- ✓ Radio telescope (high sensitivity wide-band pulsar detection)
- ✓ Multi-baseline interferometer observations and analysis
- ✓ Massive MIMO

Description

We offer different models of multi-channel coherent transceivers to meet your requirements. The current realization of the single channel transceiver is based on the RTL-SDR from Realtek (receiver only) and ADALM-PLUTO SDR from Analog Devices. We plan to add support of other single channel receivers in the future. All our models have been designed to be as flexible as possible using integrative construction components, thereby, a configuration change of the whole system (e.g. number of channels, addition of different filters, converters etc.) easily possible. Every coherent transceiver has an integrated extension card that provides flexible and expandable connectivity for specific applications.

Moreover, we provide different types of extension cards for the RTL2832U (or RTL2832U-shields) and ADALM-PLUTO SDR. These cards either enhance the characteristics of the single channel receiver (e.g. Filter or Band Extensions), or are used as building blocks to construct the coherent receivers/transceiver (e.g. Clock or Expansion Cards).

The TROxs are available in varied configurations. The figure below presents the sample configurations for the implementation of the coherent transceiver up to 8 channels using the PLUTO-SDR radio module and the CLK_CARD_PLUTO (Clock card Pluto). The clock card supports two operational modes:

- synchronisation from an external source, e.g. 10 MHz
- synchronisation from an internal source, e.g. standard TCXO 10/40 MHz

N-Channel Scalable Coherent Transceiver

CLR_CARD_PLUTO 40 MHZ

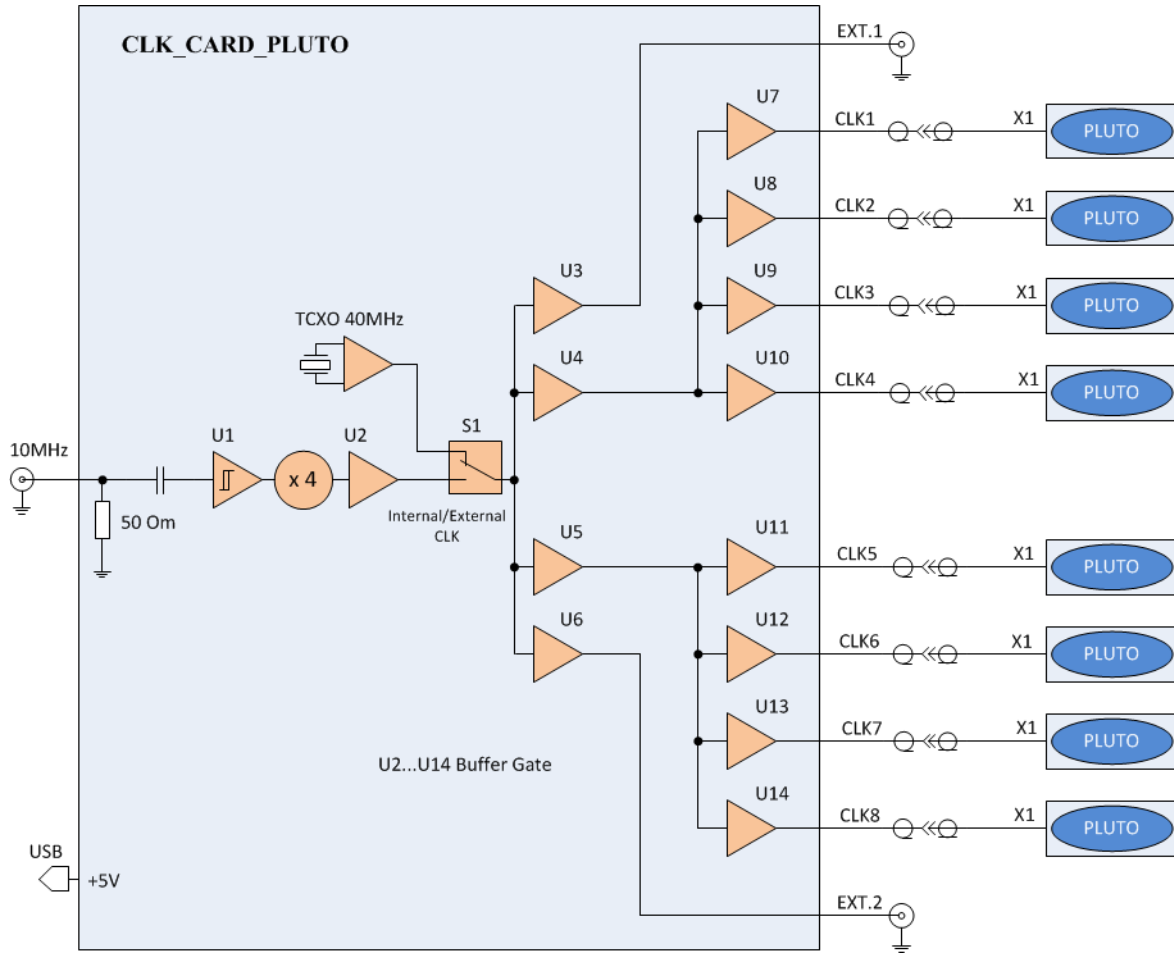

Technical characteristics (pro channel)

- ✓ ADC and DAC resolution: 12 bit
- ✓ One transmitter and one receiver
- ✓ Half or full duplex
- ✓ Clock: 10/28.8/40 MHz
- ✓ Temperature compensated oscillator (TCXO): 2 PPM. Higher precision, e.g. 0.1,0.2, 0.5, 1.0 ppm, available on request.
- ✓ Female antenna port : SMA
- ✓ 325 MHz - 3800 MHz (70 MHz – 6000 MHz on early releases)
- ✓ USB 2.0 interface; USB powered
- ✓ GNU Radio and MATLAB integration
- ✓ Operation temperature: -10 to 60 °C

Contact

For more information regarding our N-channel scalable coherent transceiver family please visit www.coherent-receiver.com.